



THE GASKET FABRICATOR

www.gasketfab.com

Volume 25 Number 3

DECEMBER 2006

In This Issue

President's Message
Page 1

Press Releases
Page 2

New Association Members
Page 2

GFA Future Meeting
Schedule
Page 2

Company Profiles
Pages 3, 5 & 6

Advertisements
Pages 4, 12 & 14-16

Member Presentations at
Fall Meeting
Page 6

What About IMDS?
Page 7

Fall 2006 Meeting Pictures
Pages 8-9

Telescoping of Adhesive
Wound Rolls
Pages 10 & 11

Technical Articles
Pages 13-14

Benchmarking Report
Page 14

President's Message

Gary Fell



As I compose this message with outside temperatures in the high 30's or low 40's, it doesn't seem possible that just weeks ago we were playing golf in Palm Springs with temperatures between 105° and 110°. The Fall Meeting was very well attended. I believe the momentum that was started at the Spring Expo carried over into the September meeting. Not only was the attendance up, the committee meetings produced positive results. There were several recommendations passed to the Board that were implemented.

The Associate Members suggested that the Board consider changing the meetings from the current Wednesday through Friday format to a Tuesday through Thursday format enabling the Associate Members to leave on Friday and be home with their families for the weekend. The Board agreed and our Spring Meeting in Savannah will follow that format. This change will also allow the Associates to attend the business meeting that is normally held on Friday morning.

The Board approved the Communications Committee's request for funds to update the GFA web site. The site has not been modified since its inception and the committee felt that updating the design to modernize it would make it more interesting to visitors.

The Program and Locations Committee and the Board discussed in detail the timing and the location for the next Gasketing/Converting Expo. Although originally scheduled for the fall of 2008, it was decided that the next Expo will be held in the spring of 2008 in the Tampa, Florida area. Steve Pendergast and Terry Galanis, Jr. were appointed as the co-chairmen of the Expo committee.

The organization is dynamic; we see the enthusiasm from new members in the committee meetings. It is your organization; you have the opportunity to make it serve your needs by being active on the committees.

Our spring meeting will be in Savannah, Georgia at the Savannah Marriott Riverfront, March 27-29. Note the change to a Tuesday through Thursday format. We will have a presentation on "Business Acquisitions" and a presentation on "Leading & Managing Today's Workplace for Tomorrow's Success". Add to that the charm of Savannah, the opportunity to network, along with the member golf outing, and additional activities for spouses. It should be a fun time especially for those of us subjected to the winter season in the Midwest.

Let me conclude by wishing everyone a Happy Holiday Season and a Safe, Healthy and Prosperous New Year. I will see you in Savannah.

PAUL GOINS NAMED VICE PRESIDENT OF TECNICOR INTERNATIONAL

Paul V. Goins has joined Tecnicor International, an importer and distributor of cork and rubber products, as Vice President for Business Development. Goins will be responsible for market development of Tecnicor's cork & rubber, rebounded rubber and flooring underlayment product lines. He will also oversee research & development of new products for Tecnicor.

Goins comes to Tecnicor from Monmouth Rubber & Plastics (Long Branch, NJ), where he served as product manager and research & development director. Goins is a native of New Jersey.

Tecnicor International distributes cork and rubber products for a variety of industries, including cork & rubber gaskets materials, flooring underlayment, fiber gasket materials, rebonded rubber, construction materials and other cork-based products. Tecnicor can be reached by calling (781) 682-1300, or through the company web site at www.tecnicor.com.

RON CLANIN, "SALES REP EXTRAORDINAIRE," PASSES AWAY AT AGE 66



Friends and clients throughout the technical foams industry are mourning the loss of Ron Clanin, who died recently at age 66. At the time of his unexpected passing, Clanin was Technical Foams West Territory Sales Manager for Armacell LLC.

He made his mark in the industry through a successful 46-year career, for the most part with RBX/Rubatex. He joined Armacell in June 2004, when the company acquired the RBX technical foam assets.

A true veteran of the rubber and foam industry, Clanin's career spanned numerous product lines and regions.

He was most noted for his ability to forge and maintain close, trusting customer relationships. Among his many professional accomplishments, Clanin was instrumental in developing supply relationships between Rubatex and several manufacturers in the Pacific Rim.

He leaves behind his wife of 44 years, Sharon, two children and five grandchildren.

NEW ASSOCIATION MEMBERS

Since the last issue of *The Gasket Fabricator*, the GFA has welcomed nine new Members. They are:

Fabricators

Denver Rubber Company
Denver, CO
www.denverrubber.com

DIGA SA de CV
Tultitlan, Mexico
www.diga.com.mx

Prescotech Industries, Inc.
Louisville, KY

Suppliers

ALS Limited
Northamptonshire, England
www.als.ltd.uk

Can-Do National Tape
Nashville, TN
www.can-dotape.com

Compac Corporation
Hackettstown, NJ
www.compaccorp.com

ITW Formex
Addison, IL
www.itwformex.com

Midway Engravers
Williamston, MI
www.midwayengravers.com

MTI Groendyk
Buchanan, VA
www.magnifoam.com

GFA FUTURE MEETING SCHEDULE

March 27-29, 2007
Marriott Savannah Waterfront
Savannah, GA

COMPANY PROFILES

ALS AUTOMATIC ROLL SLITTERS

ALS Limited is a family company based in the UK manufacturing a range of high precision roll slitting machines. We specialise in slitting foam, rubber (cured and uncured), graphite, cork, all adhesive tapes, PVC, glass cloth, textiles, polyester masking films, felt and many other rolled products. The founder of the company worked for many years in the converting machinery industry and formed ALS to meet the demand for reliable, accurate and productive log slitters. Together we have over 100 years of experience in quality slitting.

All machines include only the highest quality components. By positioning the blade to an accuracy of 0.001" we are able to reduce waste and increase yields.

Our automatic machines range from 12" to 28" diameter and up to 84" working width. We have both economy models for cost effective solutions and top of the line "intelligent" machines for customers that require greater flexibility and functionality.

We strive to incorporate new technology in our machines and key features include: automatic grinding of the blade, blade angling facility to enable accurate and straight cuts through the material, powered roll support to ease loading and unloading, blade detection device to eliminate breakage when changing blades, laser detection for blade size and auto setting, blade safety guard to protect operators when loading/unloading, automatic greasing of critical areas etc.

All ALS machines incorporate touchscreen controls for ease of use. Within the programme we can store a minimum of 60,000 cutting programmes which ensures instant set up when changing jobs. The programmes include Help screens for the operators together with fault finding advice if required for example, "Guards open."

We deal directly with US companies to give our customers the best attention at all times. ALS provide service support both from the UK and also out of Chicago. It has been company policy from day one to only use standard parts that are readily available to customers worldwide. The machines can also be supplied with a network connection for remote diagnosis from ALS.

We are very pleased to become a member of the GFA and recognize it as a very important industry, Spencer Lack states "many of our customers are already members and it is the perfect place to meet."

We also supply sheeting machines and slitter rewinders through our sister company John Lack Equipment for installation in the USA.

COMPAC CORPORATION

Compac enjoys the reputation as a leader in coating, laminating and converting flexible substrates. At Compac, our philosophy of doing business can be summarized in three words: speed, flexibility and innovation.

We serve four primary markets— construction, industrial, automotive and electronics—and bring over fifty years of quality, experience and expertise to the table. At Compac, we place the highest priority on meeting our customers' needs, dedicating our resources to solving technical and application problems, while creating customized products, and providing exceptional service.

We are located in Hackettstown, NJ in a new 182,000 square-foot manufacturing and distribution center. We are ISO 9001 certified, and have a staff of R&D specialists with extensive experience in polymer chemistry and materials engineering to solve all of your needs for new product development of pressure sensitive adhesive tapes for the foam fabricating industry.

JOHNSON PACKINGS

Founded in 1926, Johnson Packings has gone through many changes, keeping up with market demands. We are one of New England's largest industrial distribution and fabrication companies. Our primary customer base includes power generation, pulp & paper, chemical processing, hydroelectric, marine and many large original equipment manufacturers.

Johnson Packings is aligned with some of the world's leading manufacturers of industrial sealing and gasketing products. Our product line and our "in-house" fabrication capabilities give us the ability to solve any gasket or rotating equipment-sealing application.

Capabilities include: CAD/CAM digital gasket fabrication, high volume, die cutting, custom, and one-piece gaskets up to 150" OD. Vulcanizing and slitting services, machined plastics operation and our cryogenic operation.

Products include: gasket material (all types), mechanical seals, pump & valve packing, oil seals, o-rings, molded rubber, metal and elastomeric expansion joints, non-metallic bearings, plastics (high performance), and water filtration.

Additional information can be found at www.johnsonpackings.com.

ADCHEM®
 The Adhesive Tape Engineers

- 40 years of manufacturing excellence—1965-2005.
- Extensive selection of adhesive systems engineered for the gasket market.
- Experienced technical staff to support your application requirements.



www.adchem.com
 Tel: 631-727-6000 • Fax: 631-727-6010
 1852 Old Country Road, Riverhead, NY 11901

DIAL DURAFOAM DIRECT

Closed Cell Sponge Rubber & Plastic Foam
 • Buns • Sheets • Rolls • Stripping •
 Sold Thru Gasket Cutters – Fabricators & Resellers
 Worldwide

MONMOUTH RUBBER & PLASTICS CORP.
 Phone: 888-FOAM-888 Fax: 800-375-1962
 E-Mail: sales@monmouthrubber.com
www.rubberplastics.com

NEW Gasketing Solutions from Armacell:

Ensolite®

SF0 (Soft Foam Grade 0)
 • Semi-open
 • Easier to skive
 • Thicker

IR 41 and IR 42
 • Excellent skin surface
 • Armacell quality



armacell
 engineered foams
 www.armacell.com
 1-800-866-5638

STG OF **Covulence Adhesives**
 SPECIALTY TAPE GROUP

Designing, manufacturing and servicing industry with quality pressure-sensitive adhesives.

A broad range of products and custom development for diverse applications and substrates.

Technical expertise to guide you to the right product for the application.

Not just adhesives. Answers.

25 Forge Parkway • Franklin, Massachusetts 02038 • USA
 tel: 800.248.7659 x1671 or 508.918.1671 • stg@covcorp.com • www.covulenceadhesives.com

Innovators of Cork and CorkRubber Products by Amorim Industrial Solutions!

Applications include:

- Aerospace
- Anti-slip
- Appliances
- Cushioning
- Friction
- Natural Gas
- Petrochemical
- Walkways
- Agriculture
- Anti-vibration
- Automotive
- Electrical Transformers
- Insulation
- Packing
- Sealing



AMORIM
 AMORIM INDUSTRIAL SOLUTIONS
 26112 110th Street • Trevor, WI 53179
 800-558-3206 • 262-862-2311 • Fax: 262-862-2500
 general@amorimsolutions.com • www.amorimsolutions.com

Rubber and acrylic-based PSAs.
 Diverse family of free films.
 High performance foam tapes.

MACtac It.
MACtac® Technical Products



1.800.328.2619
 MACtactechnical@bemis.com

REEVES MATERIAL SOLUTIONS

Years of experience and continued success make Reeves' coated fabrics and unsupported rubber sheet the most trusted in the market. Engineered for dimensional stability, broad temperature ranges, high and low pressure regulation, impermeability to gases and liquids, and antiwicking properties, our thin gauge-tight tolerance products are the first choice for mechanical applications.



REEVES
www.reevesbrothers.com • 864.595.2220

NOW READILY AVAILABLE FOR INDUSTRIAL APPLICATIONS.



Target Marketing is pleased to announce that they are the Marketing and Distribution Center in the USA for Victor Reinz premium grade sealing products for industrial applications.

Target Marketing, Inc.
 P. 412-486-2627
 F. 412-486-0914
 E. targetm@nauticom.net
 www.target-marketing.us

- Premium compressed non-asbestos sheet
- Rubber covered metal/embossed gaskets
- High temperature mica

VICTOR REINZ
People Finding A Better Way

COMPANY PROFILES

INTERSTATE SPECIALTY PRODUCTS

*Precision Die Cutting And
Gasket Fabrication
For Industry*

Since the ambitious start of our business in 1963, Interstate Specialty Products has been working hard to build a solid reputation for unfailing quality among an ever-expanding list of blue chip customers.

To maximize the skills of our talented staff and streamline our operations to meet 21st Century demands, we have moved recently into a state-of-the-art facility in Sutton, Massachusetts.

Here in our new headquarters, we have a comprehensive array of cutting-edge manufacturing equipment to fabricate just about anything our customers can imagine — from miniature die cut products to large industrial gaskets over 60" in size. We have recently added a digital die less cutting system that is perfect for rapid prototyping and difficult parts.

ISP competence and innovation are recognized in industries as diverse as consumer products, scientific and biomedical applications, filtration systems, and chromatography and diagnostic devices — to name only a few in a long list of challenges and successes.

All this is enhanced by a new integrated software system that supports our entire manufacturing stream from start to finish — allowing us to track jobs in real time, to better serve our customers, and to meet even the most critical deadlines.

Above all the technology, we are still a very people-to-people oriented business. Customers particularly like the well-knit performance of our in-house team that has been together for years and has worked closely to develop creative solutions for very demanding, highly complicated applications.

Major industries served by Interstate Specialty Products include: Scientific, Medical, Homeland Security, Diagnostic, Marine, Electronic, Recreation, Military, Consumer, Industrial, and Transportation.

www.interstatesp.com
Tel: 800-984-1811
Fax: 508-234-5558

ITW FORMEX

1701 W. Armitage Court
Addison, IL 60101
Ph. 630-889-8655
www.itwformex.com

ITW Formex is a division of Illinois Tool Works, a Fortune 200 company. ITW Formex manufactures the Patented UL-94 V0 Flame Retardant, RoHS and WEEE compliant polypropylene material known as Formex. The material comes in rolls and sheets from .005 to .125 mils (127 to 3.18 mm) and can be fabricated for use as an Electrical Insulator, Barrier, or in lieu of Internal Metal or Injected Molded Parts.

Our key markets include, Computer and Computer Peripherals, Power Supplies and UPS Systems, Electrical and Power Distribution Systems, Medical, Telecommunications, Automotive, Appliance, TV and Entertainment Industry, and many other industries requiring electronic or electrical systems.

Applications for Formex include Electrical Insulators and Barriers between PC Boards and Housings, Barriers to prevent reaching into high voltage areas, Internal Parts i.e. Air Flow Baffles, Wire/Cable Harness Organizers, EMI/RFI Shielding, Brackets, Covers, etc.

ITW Formex materials are all UL-94 V0 Flame Class Rated and meet Global Safety Standards. Formex is non-hygroscopic, therefore, parts remain dimensionally stable and will not reduce in dielectric strength. Formex is RoHS and WEEE compliant. Formex is Chemical Resistant. Formex has Excellent Dielectric Strength (i.e. GK17=24,480 Volts). Formex has superior Score and Folding Capabilities and will not crack or split like so many other insulation materials. Formex is the most economical insulation material in the world market today because of its many unique properties and low cost.

MTI GROENDYK

MTI Groendyk, Inc. is a world-class manufacturer of high quality silicone elastomers and organic rubber products with over 40 years of experience in the industry. Our ability to manufacture sheets, rolls, extrusions, and molded parts, as well as our experience with all types of polymers makes us a one-stop shop for all of your material needs. In house mixing and diverse manufacturing methods allow us to customize materials and products to meet your toughest specifications. Groendyk regularly manufactures materials for unique colors, extreme high or low temperatures, chemical and fire resistance, thermal conductivity, and electrical conductivity.

Continued on next page...

COMPANY PROFILES

MTI GROENDYK

Continued...

Our materials are qualified for aerospace, defense, automotive, and other demanding environments. MTI Groendyk supplies sheets, rolls, and bun stock from the very lightest open cell silicone foam to 80 durometer solid silicone. Thicknesses range from 0.005" to 10".

MTI Groendyk also provides value added services that include pressure sensitive adhesives; hot vulcanized joining, slitting, stamping, and splicing. MTI Groendyk is part of MTI Global, Inc., with manufacturing locations in the United States, Mexico, Germany, France and Canada. These production facilities work in concert to offer our customers many diverse capabilities and a wealth of experience to assist in meeting your needs.

We are an ISO 9000:2001 certified facility, and are proud to provide quality, delivery and excellent value to our customers.

Please visit our website at www.magnifoam.com, or call our sales and customer service center at 1-800-624-3626.

MEMBER PRESENTATIONS AT FALL MEETING

At the Fall Meeting in Indian Wells, California, presentations were given by Jim Mallace with 3M and Dan Putnam with Lauren Manufacturing. Following are the summaries they provided.

3M

3M™ Double-Coated Transfer Tape

Now you can get the flexibility and easy handling properties of an adhesive transfer tape with the stability and die-cutting capability of a double coated tape. 3M™ Double Coated Tapes 9786 and 9786NP deliver exceptional versatility and performance at a very attractive price.

It's a double coated tape that doesn't handle like one. The thin, non-woven carrier provides outstanding flexibility for easy handling, so it's an ideal choice for gasket and foam attachment. You can get into corners and around curves where a polyester-carrier tape might not conform. But, you still get the structural support and precision die-cutting that come with double-coated construction, making it ideal for general purpose applications as well.

And 3M tapes 9786 and 9786NP feature our proven 3M™ High Strength Acrylic Adhesive 300MP, which means you get exceptional adhesion with impressive

peel strength on a wide variety of surfaces ranging from stainless steel, rubber, and polycarbonate to felt, open-cell foams, and non-woven fabric parts.

It's a winning combination of performance, productivity, and price.

3M™ R³ Program

(R³ : Rapid. Responsive. Reliable.)

3M has always provided you with tape solutions that are reliable. But in some applications your needs didn't always fall into the standard off-the-shelf configurations, and that meant waiting for a custom solution to be created. But in today's fast-paced marketplace, lost time means lost sales.

You need a solution that's responsive—something with the performance to keep up with the rapid pace of the industry. That's why we created R³. Now you can get custom combinations of top quality 3M components to meet your customers' needs, fast. How fast?

Our goal is to get you:

- PRICING AND FEASIBILITY IN 1 DAY
- SAMPLE ROLL SHIPPED WITHIN 7 DAYS
- FIRST ORDER SHIPPED IN 21 DAYS

R³ provides you with flexibility like never before.

We've streamlined our operations to maximize efficiency across the board. We are stocked with a wide array of adhesives, liners, and carriers so we can get samples customized to your requirements quickly. And we offer years of industry knowledge and expertise so you know you're getting just the right combination of components for maximum performance.

Minimum orders start at just 1.5 mil square inches or five master rolls by 180 yd. Call your 3M rep today and ask about R³. It'll change the way you think about custom adhesive solutions from 3M.

LAUREN MANUFACTURING

Sealing Solutions

Sealing needs are very diverse in many market segments such as automotive, industrial, home and construction. The presentation identified many types of products that are used for sealing applications. The various materials and compounds that are used to manufacture these products were also identified, and basic physical properties were outlined.

Descriptions were given of the various manufacturing processes that are used to manufacture the final products. Applicable universally accepted standards for testing of both materials and products, such as SAE - ASTM - GFA - UL - RMA - were noted.

During the presentation summary an outline of Lauren International, and the wide variety of products that this international company offers were introduced.

WHAT ABOUT IMDS?

By: Mike Scarpelli, QA Manager
Everseal Gasket Inc.

The International Material Data System (IMDS) was created as a joint venture project of Audi, BMW, Daimler Chrysler, Ford, Opel, Porsche, VW and EDS to provide a secure online database of Material Data Sheets attached to OEM part numbers. This system was set up to allow the automobile companies to comply with the voluntary EU directive that 95% of a vehicle be re-useable by 2015. It also simplifies current RoHS Directive compliance by automatically highlighting restricted substances on the MDS.

The system allows material manufacturers to control who has access to their Material Data Sheets, and for using ingredient percentage ranges to protect formulas from competitors.

Composition, distribution and storage are all accomplished within the system.

Getting Started:

Participants need to direct their browser to www.mdsystem.com/html/en/home_en.htm and click "System" and "Online Registration", if you are not sure whether your company is registered, follow the instructions on the home page. I would recommend downloading the IMDS User Manual .pdf file to assist you with navigating the system.

FABRICATORS: After you receive your user name, account ID number and password you can log on to the system by clicking "System Access" then "Log On". Once you are logged on you can create an MDS. I usually call the material manufacturer and request an MDS be sent to your company's account ID number. You can also request one by using the MDS Request function. After receiving the MDS just attach it to your part number ("Component") as a "Material" by looking it up by material number, description or trade name. Don't forget to answer the "Polymeric parts marking" question, we have had to go back and modify several MDSs because we did not know this was a requirement.

When you have completed the MDS, look up your customers name and send the MDS to them for approval. Don't worry about making a mistake because the system automatically checks your work and if it finds an error it tells you about it and gives you a link to the incorrect section so you can fix it.

Then you just "Next" back to the last screen and click "Send". You can check on the approval status of your MDS by checking your "Messages".

MANUFACTURERS: All raw material suppliers to OEM automotive should already have an IMDS account. If not, set one up as described above. Then set up your product as a "Material" by adding ingredients to the "tree". The system has a listing of every "Basic Substance" and you build the MDS from this list. The automatic MDS checking features will advise if any mistakes are made and assist you with the corrections. If any substance is restricted, your customers may not approve the MDS. Some customers may allow some flexibility in what substances are allowable but manufacturers should have a plan in place to replace that ingredient if possible. When a request for an MDS is received from a customer, the manufacturer simply sends that MDS via the system to the requestor who has the responsibility to attach the MDS to the part number specific MDS they are composing for their customer.

NEWSLETTER

The Gasket Fabricator is published by the Gasket Fabricators Association and distributed to all members and prospective members of GFA.

PresidentGary Fell
Vice President.....Clem Foley
Executive Director..... Robert H. Ecker
Administrative Director/Newsletter Editor..... Peter Lance
Communications Committee Chair.....Jim Winchell

Members are encouraged to contribute articles and items of interest to the *Gasket Fabricator*. All contributions should be addressed to: Executive Director, GFA, 994 Old Eagle School Road, Suite 1019, Wayne, PA 19087-1866, Phone (610)971-4850, Fax (610) 971-4859, Home Page: www.gasketfab.com, E-mail: info@gasketfab.com.

Articles appearing in this publication may not be reproduced without written consent from the Association. Articles appearing in the *Gasket Fabricator* are the views of the authors and not necessarily those of the Association.

© Copyright 2006 Gasket Fabricators Association

FALL 2006 MEETING HYATT GRAND CHAMPIONS, INDIAN WELLS, CA



Gary Fell,
President of the GFA,
at the Semi-Annual Dinner



Newlyweds Pam and Demitri
Fardelos



Gary Fell presents Paul Yager with a
plaque for his contributions on the
Board of Directors



Jeff Dietrich with the
Institute for Trend Research,
presenter at the General
Session



Scott Schmidt with
Black Line Group,
presenter at the General
Session



Terrell and Takako, entertainers at
the Semi-Annual Dinner



First Time Attendees (left to right):
Shirley Monte, FLEXcon; Kingdon Offenbacher,
Echo Engineering; David Williams, Dodge-Regupol;
Charles Rustem, MACtac; Sue Ohrman and Rocky
Trudell, ITW Formex



First Time Attendees (left to right):
Mike Maguire, Compac Corporation; Mike Dow,
Adchem Corp.; Craig Anderson, Zone Distributing;
Beth and Mike Dover, Precision Industries Corp.;
Mark Hemphill, Reeves Brothers

SUPPLIER EXPO



Bob Ecker, Executive Director, visits with former GFA Member, Clyde Howard

TELESCOPING OF ADHESIVE WOUND ROLLS

By: Dr. David R. Roisum,
Finishing Technologies, Inc.

The following is part one of a two-part article. Part two will appear in the March 2007 issue.

Many web products, such as tape and labels, are coated with an adhesive. A common class of adhesives for such products are called PSA's or Pressure Sensitive Adhesives. These adhesives have conflicting design requirements. In order to use them, you must be able to peel the layers from the unwinding roll. However, in final application you may want the product to stick aggressively enough so that it can't be removed from the mating surface. Examples include price stickers and warning labels. The adhesive may need to be tacky or at least not brittle at low temperatures while at the same time having an adequately high shear strength at high temperatures. This design challenge is analogous to multi-viscosity oils that seemingly defy nature by being more fluid at low temperatures and less fluid at high temperatures than would otherwise be expected.

The design challenges are not limited to final product characteristics. The adhesive must have viscosities that are compatible with one or more of the commercial web coating methods. It can be difficult to coat with high shear adhesives, especially at low coat weights and/or high speeds. These web products are often wound into master rolls after adhesive coating. The master rolls are then stored for minutes to months before the next operation that may be coating, laminating, printing or slitting. Finally, the master rolls are cut into smaller final product rolls. The master rolls could weigh several tons while the final product rolls, such as a roll of masking tape, may be small enough to fit in your hand. The problem is that the wound rolls can misbehave, even while merely sitting in storage.

The Challenge Of A Round Roll With Straight Edges

Winding a roll that has straight edges can be a challenge in its own right. Certainly the web needs to have an adequately level tension profile else bagginess can cause tracking problems. Certainly the web needs to have an adequately level gage profile else the roll may telescope to the heavy side while winding.

Similarly, the winder must be aligned, mechanically tight and stout enough to avoid excessive deflection. The roll must wind without excessive vibration. Tension and nip must be set appropriately and tightly controlled. These and many other factors must be tended to in order to make straight-edged rolls. However, merely making a roll with

straight edges does not mean that it will stay that way. We are all familiar with the roll of adhesive tape that may have had straight edges for months. Take that roll and put it in the back window of a car parked in the sun. It may not take many minutes for the previously well behaved roll to shoot out sideways. This defect is given names such as coning, plating, telescoping and others that are not printable here. While not all adhesive rolls do this, they all have the *tendency* to do this.

Related problems are common with master rolls, especially if they are large. If a large roll is core supported on racks, the roll may go egg-shaped. If you support it on the bilge, the roll may slowly develop a flat spot. Rolls that lose their roundness are difficult to unwind at high speed. The loping runout causes tension fluctuations that can upset delicate processes like printing registration, but may even trouble normal web handling.

Driving Force Due To Winding Pressure

To diagnose the movement of the roll, we must answer two questions. First, what forces were present that drove the movement of the roll? Roll movement could be reduced by reducing those forces. Second, what allowed movement of the roll? Roll movement could be reduced by reducing the freedom of the roll to move. One force that is always present in a wound roll is interlayer pressure. This pressure is caused in part by wound-in-tension which in turn is caused by the TNT's of winding, namely, Tension, Nip and Torque.

However, the interlayer pressure is determined even more strongly by material properties such as MD and stack modulus. Not only is this interlayer pressure inevitable, it is desirable for most products. The mechanism that holds wound rolls together is friction between the layers. If the friction is insufficient, the roll may go out of shape in a variety of ways. This friction is a byproduct of both the interlayer pressure and the web-web coefficient of friction. Ironically, the pressure that holds a roll together be at the same time destabilizing. The pressure from the outer part of the roll compresses the inner portion. This is analogous to axial compression of a yardstick. If the force is high enough or the yardstick slender enough, the stick will buckle sideways. The roll analogy is an axial or sideways telescoping movement. Not surprisingly, we will find that the tighter you wind the outer layers of the roll, the more likely the roll will telescope. Thus, winding at low tensions or at least finishing at a low tension through aggressive

Continued on next page...

Continued...

taper would be one strategy to combat this type of telescoping. It is the force of winding that supplies the energy to drive the roll sideways. However, product design is also contributing. The higher the aspect ratio, which is roll diameter divided by roll width, the greater the risk. We also know from buckling theory that any eccentricity of the column in compression will reduce its ability to withstand buckling. In other words, a warped or crooked yardstick can carry less load. There are two analogies in the wound roll. The first is a roll that does not have straight edges. The second is a roll whose pressure profile is not level due to an asymmetric gage profile problem. The overhung pressure creates a bending moment that pushes the roll further away from the overhang. The movement of an initially (nearly) straight roll will progress. At first, the movement is slow because eccentricity or lack of roll edge straightness is low. However, as the roll center pushes outward, the bending moment gathers strength that exaggerates the thrust force. Finally, the movement slows as the roll pushes sideways enough to relieve much of its stored energy.

To determine whether poor initial straightness contributes can be simple. If the roll is wound with a dished edge, the risk of telescoping in storage is increased. If the core's edge does not extend to the roll's edge, the risk is also increased. To determine whether gage profiles contributes is usually simple. If the roll moves toward the harder/larger side of the roll as measured by gage, hardness or diameter, then profile is likely involved. On many machines, the caliper or gage tends to have a smile or frown profile. If so, the end rolls will be more troubled by dishing during winding and telescoping during storage.

Driving Force Due To Gravity

It is hard to avoid gravity, yet this is the driving force that causes rolls to get out-of-round during storage. The roll will sag into an egg shape with core support storage. To reduce the force, we would need to reduce the diameter of the roll. To spread the force out over a wider area, we might increase the core diameter.

The roll will develop a flat spot when stored on its bilge. To reduce the force, we would again need to reduce the diameter of the roll. To spread the force out over a wider area, we could support the roll on a sling. In fact, the sling is simple to make and is usually the gentlest form of roll storage. An unusual storage alternative is to continuously rotate the wound roll at a frequency fast enough keep a set from developing. This might be less frequent than a rotation per day in more robust products to a more frequently than a rotation per hour in less stable products. Some products, however, can not be rotated in one or

possibly both directions without causing the very problem it was trying to treat, namely, telescoping.

The effect of time on egg-shaped rolls is a little different than with telescoping. While the tendency is also a progression with time, the severity of this defect is often proportional to log time. Recall that in the case of winding pressure-induced telescoping, we would like to reduce tensions so that driving forces are minimized. Curiously, in the case of egg-shaped and flat-tire rolls, we usually want to increase tension. In this case, interlayer pressure is helpful to keep the layers from shifting minutely.

Role Movement - Micro Sale

A roll which changes shape does so because layers are slipping and sliding on each other. The layers may slide during winding, storage or unwinding. Strictly speaking, the common defects that result are termed dishing, plating and telescoping respectively. Some people have trouble accepting the fact that the layers slid, perhaps because they are visualizing sliding like locking up the tires on a car. However, it takes very little layer-to-layer movement to cause large telescopes.

We can easily calculate the results of micro-slippage as follows. Let us assume a mere 1 mil (0.001" or 25 microns) of movement of one layer upon the next. If the web were 2 mils thick, representing thick film or thin paper, there would be 500 layers in a one inch stack of material. The total movement of that inch of material would be 500 x 0.001" or "" (12 mm). While the movement per layer is quite small, the accumulated effect is a large dish or telescope. If you looked quite close, you can sometimes observe this micro-slippage on rolls with cleanly slit edges. The roll edge has a stair-step appearance. Also, you may uncover adhesive so that the roll edge feels tacky or greasy, as the case may be.

Another reason that people have difficulty accepting the notion of slippage is that certain materials that telescope appear to have high interlayer friction. Tissue, for example, is quite prone to interlayer slippage under a rolling nip, even though the web-web coefficient of friction is around 1.0. The nip in this case may be at the inside of the roll due to supporting the weight of the roll at the core or at the outside of the roll caused by a layon roller or drum. In any case, the layers in bulky materials such as tissue, nonwovens and textiles do tend to slide. All one needs to do is draw a radial line on the edge of the roll. After further winding or unwinding, the line will shift into a J-shape. The radial line technique is one of the most powerful tools to diagnose telescoping during winding or unwinding. Similarly, intuition can be a barrier to accepting that adhesives also slip. However, as will be shown next, most adhesives behave more like grease than glue.

Part two of this article will appear in the next issue.



ROGERS CORPORATION

PORON® Urethanes and **BISCO®** Silicones, materials that offer a broad range of design solutions for gasketing, sealing and energy absorption. To request a **FREE** copy of our *Sealing and Gasketing Design Guide* call our Solutions Center at 800.935.2940 or 607.786.8112 or visit us on-line at www.rogerscorporation.com/hpf.

FOR TROUBLE FREE GASKETS... YOU NEED QUALITY SHEET RUBBER



AMERICAN BILRITE SHEET RUBBER



American Bilrite, 440-B Britannia Rd. E. Mississauga, ON, Canada L4Z 1X9
Toll Free Tel: 1-877-436-7763 Fax: 905-507-2388
E-mail: gp@american-bilrite.com



Gaska Tape Inc.
INNOVATORS IN FOAM AND TAPES

P.O. Box 1968 • Elkhart, IN, 46515
Phone 800-423-1571, 574-294-5431 • Fax 574-293-4504
Email sales@gaska.com • www.gaska.com





Innovative Solutions In Foams and Tapes



80 East Morris Street
Philadelphia, PA 19148
Phone: 215-271-0610
FAX: 215-271-3305

Acrylic and Rubber Tape Bonding Solutions



www.cctapes.com

Adhesive Products That Perform

America's Choice for Quality Rubber.™

CALL TODAY for all your rubber requirements



Rubber Sheeting



Extrusions & Splice



Molded Products

WARCO®
West American Rubber Company, LLC

714-532-3355
Fax 714-532-2238
www.warco.com

Quality rubber products for industry and defense since 1910.



800-858-0482
www.brpmfg.com

BRP Manufacturing Company
Industrial Rubber Sheeting & Molded Product

*1/64" to 3" Thick • Slit to Width
Buffed to Tight Tolerances
Adhesive Ready with Paper Interleaf
Cloth Inserted or Unsupported*



Automatic Roll Slitters



Precision roll slitters for:

- * Foam
- * Rubber
- * Graphite
- * Cork
- * Adhesive tape
- * Felt
- * Foil

www.als.ltd.uk info@als.ltd.uk
T. 011 44 1933 225755 F. 011 44 1933 441476



chemprene

Precision Engineered Rubber Coated Fabrics

Your source for elastomer coating of:
Nitrile - Neoprene - Silicone - Fluoroelastomer - Butyl

Coatings on:
Polyester - Nylon - Cotton - Fiberglass - Aramids

483 Fishkill Ave., Beacon, NY 12508, (T) 877 -340-2088, (F) 845-831-4639
www.chemprene.com

TECHNICAL ARTICLES

By: Larry Pyle, LFPtechnologies

ASTM STANDARD TESTS FOR GASKET MATERIALS

The following article is the first of a series that will describe, in layman's terms, each of the Standardized Tests that are routinely performed on gasket and gasket type materials. Although limited in scope, they provide for the comparison of basic performance properties of different grades of material. Special thanks should be given to **Ken Ko** and **Jeff Kane** of **Interface Solutions Inc.** for their material input in preparing this series of articles.

ASTM SPECIFICATION F 38-00, STANDARD TEST METHODS FOR CREEP RELAXATION OF A GASKET MATERIAL

Discussion: The two test methods described in Specification F 38-00 are designed to compare related materials under controlled conditions and their ability to maintain a given compressive stress as a function of time. A portion of the torque loss on the bolted flange is a result of creep relaxation. Torque loss can also be caused by elongation of the bolts, distortion of the flanges, and vibration: therefore, the results obtained need to be correlated with field results. In both tests methods, which will be described in more detail, the specimen is subjected to a compressive stress between two platens, with the stress applied by a nut and bolt. Stretching the bolt a fixed amount controls the amount of stress or load. Method A is used infrequently because it is normally limited to room temperature testing. Method B is the test of choice since it can be used at a variety of elevated temperatures. If a more precise, step-by-step description of each test method is desired, consult the ASTM F 38-00 Specification.

Test Method A (see Fig. 1) is normally run at room temperature, the stress is measured by a calibrated stain gage on the bolt. In running the test, strain indicators

readings are taken at intervals of time, beginning at the loading, to the end of the test.

The strain indicator readings are converted to percentages of the initial stress that are then plotted against the log of time in hours. The percentage of initial stress loss or relaxation can be read off the curve at any given time, within the limits of the total test time. A minimum of three tests are required on each material to be tested.

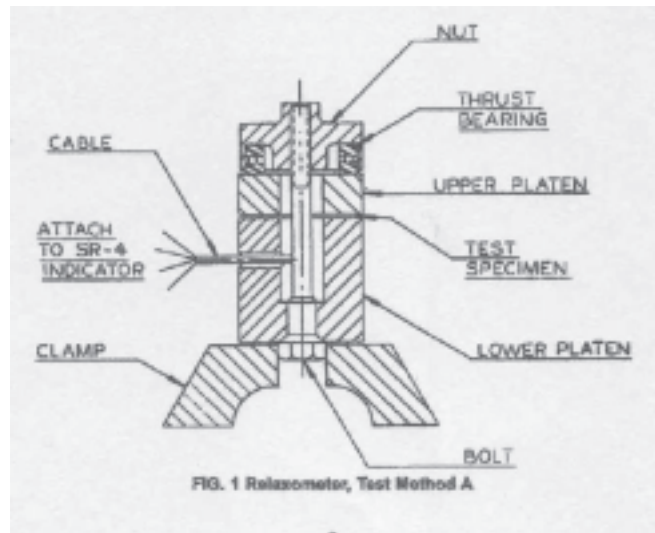

FIG. 1 Relaxometer, Test Method A

The sample consists of an annular ring with an OD of 2.060 inches, ID of 1.300 inches for an area of 2.0 square inches.

The normal design stress is 2000 psi or 4000 lbs for the 2 sq. inches. The load is applied by tightening the nut with a wrench in one continuous movement until the desired stain is reached. This should take no less than 8 seconds or no more than 12 seconds to perform.

Test Method B (see Fig. 2) can be run at room temperature, and at elevated temperatures up to 400 degree F. The fixture that is used is called a Relaxometer and is composed of two platens, special drilled and calibrated bolt, washer and nut composed of hardened steel (typically A 193 Grade B7 or ASTM B 637 Grade UND) which satisfy the calibration procedure for the test temperature specified 70, and a dial indicator as shown in Fig. 2.

Continued on next page...

If you have technical questions you would like to see answered in future issues, please send them by e-mail to lfptech@sbcglobal.net.

TECHNICAL ARTICLES

Continued...

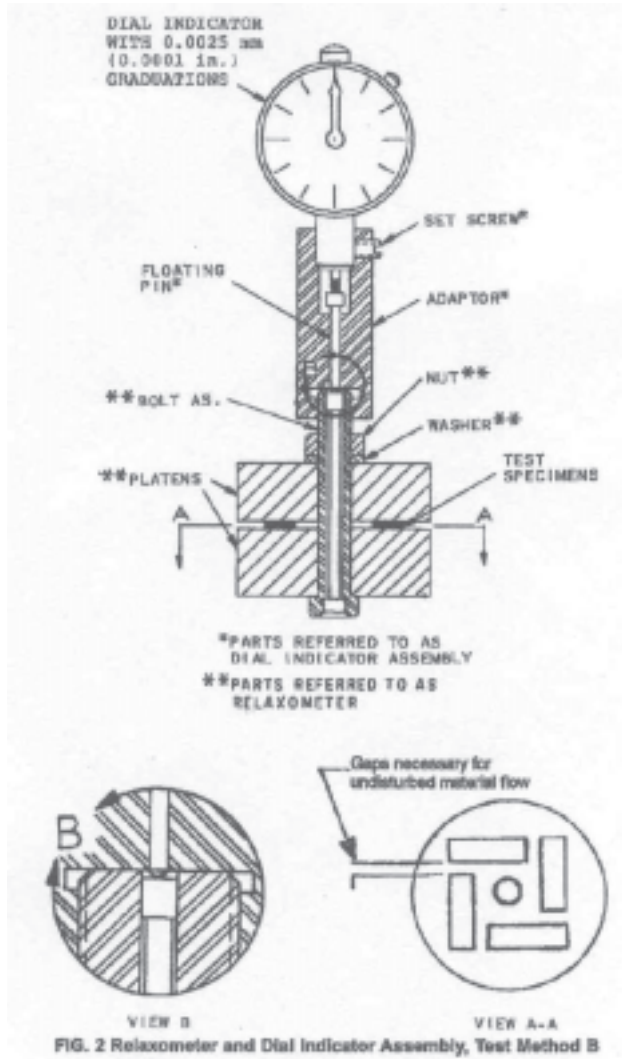

Each bolt has a drilled center hole in which a machined pin is inserted, press fit at the head of the bolt, free and ground flush at the other end. As the torque is applied to the bolt with a wrench, the outside stretches while the center remains at its' original length.

The difference is measured with the dial indicator at torque-up and after the entire fixture and sample has been subjected to the prescribed temperature for the prescribed duration. The bolt is designed to stretch .0048 to .0050 inches at 6000 lbs force. The tests are typically 22 hours at temperature with a 2 hour cool-down before measuring the retained bolt stretch. Results are reported in terms of stretch loss as a percentage of the initial stretch.

Each sample consisted of four (4) pieces 1.25 inches by .40 inches (2 square inches). This means that the initial stress on the sample is 3000 psi, higher than for Method A. As stated earlier, Method B is generally preferred to Method A because of the wider range of temperature conditions that can be simulated.

BENCHMARKING REPORT

The following are the results from our benchmarking report. This report was undertaken to give GFA members a thumbnail sketch of how other members are fairing at this time.

We had 35 out of 66 Fabricator responses.

1. Most Recent Quarter Sales Compared to Previous Quarter

UP	DOWN	SAME
23	7	5
66%	20%	14%

2. Current Quarter Sales Projection Compared to Last Quarter

UP	DOWN	SAME
20	9	6
57%	26%	17%

We had 23 out of 53 Supplier responses.

1. Most Recent Sales Compared to Previous Quarter

UP	DOWN	SAME
18	3	2
78%	13%	9%

2. Current Quarter Sales Projection Compared to Last Quarter

UP	DOWN	SAME
15	3	5
65%	13%	22%

FOAM SOLUTIONS

Volara®, Volextra® & Minicel®
customized designed polyolefin foams all with distinctive features and benefits to help solve your unique challenges.

Sekisui Votek, LLC
106 Shepard Street
Lawrence, MA 01843
9803 225-0050
www.SekisuiVotek.com

Manufacturer of Acrylic and Rubber Based Pressure Sensitive Films for Foam Laminat on

VentureTape®

Venture Tape Corp., 30 Commerce Road, Rockland, MA 02370
 800 343-1076, 781 331-5900,
 Fax 781 871-0065
 www.venturetape.com



Exclusively from Compac... NetBond™
transfer tape with embedded scrim

- Ensures the dimensional stability of foam gaskets
- Acrylic adhesive flows into the substrate forming strong bonds
- Two grades of NetBond... a perfect fit every time, everywhere

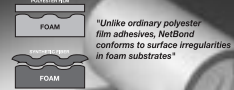

In Addition...
 • Compac polyester film tapes with rubber and acrylic adhesives
 • Custom solutions to satisfy your special requirements



Where innovative ideas take hold.

Get all the facts at our web site: www.compaccorp.com

103 Bilby Road, Hackettstown, NJ 07840 • Tel: (877) 526-6722 • Fax: (908) 850-0272



VALU-EDGE™
 Wagner Products & Technical Support

Valu-Edge is Wagner's commitment to providing our customers with the best in quality, value, service and training. Get the edge - Valu-Edge exclusively from Wagner Die Supply!



Ontario, CA • Dallas, TX • Elmhurst, IL • Tacoma, WA

(800) 423-4478

www.wagnerdiesupply.com

ISO 9001: 2000
 CERTIFIED

We have the sealing products and the technical expertise to help you succeed



- KLINGERSIL® compressed and beater addition gasket materials
- Thermoseal® soft-chem® expanded PTFE material
- KLINGER® top-chem PTFE products
- Sealex® PTFE joint sealant

Thermoseal Inc • 2350 Campbell Rd • Sidney, OH
 800-990-SEAL • www.thermosealinc.com

DODGE-REGUPOL INCORPORATED
 leaders in recycled product technology
www.regupol.com

- Ranked #89 in RPN's "North American Rubber Industry Top 100"
- 133-year history of dependable domestic supply of cork & cork/rubber products to gasket fabricators & OEM community
- North America's leading developer of rubber products, including masticated, neoprene, nitrile and recycled SBR materials
- NVLAP accredited in-house lab tests and certifies materials to ASTM, SAE and Military standards

Julia Hollern
 Phone: 1-800-333-1933
 Fax: 1-717-295-3414
 Email: jslme@regupol.com

LUDLOW Composites Corp.
 2100 COMMERCE DR. • FREMONT, OH 43420
www.ludlow-comp.com

Manufacturer of PVC foam for gasketing, seals, weather-stripping, sound deadening and vibration dampening.

industrialsales@ludlow-comp.com

800-628-5463 Fax: 419-332-4180

{ ACRYLIC DOUBLE-COATED TAPES FOR ALL YOUR FOAM GASKET ATTACHMENT NEEDS. }



For more information visit us at WWW.3M.COM/CONVERTER



High Performance Sealing Solutions

MicroPore® technology outperforms conventional gasket materials in a wide range of automotive and industrial applications. Value Grades provide assured availability, fast delivery and application testing.

1-800-9GASKET • Tel: 717-207-6000
 Fax: 717-207-6080 • www.sealinfo.com



Technically Reliable. Cost-Effective Solutions



Preco provides both die cutting and laser expertise for the gasket industry. Together, we can find the right solution for you, whether it be a standard system, custom system or contract manufacturing service.

Partner with Preco: 800.966.4686 | www.precoinc.com



Looking to Lower Costs?
 Let Zone Distributing Connect You to China. 20% Off Domestic Prices.

- Foam & Rubber Goods
- Foam Tapes and Pressure Sensitive Adhesives
- Packing Materials and Cartons

314-771-7107
 www.zonedist.com



Engineered Products... Innovative Thinking

- Manufacturer of Industrial, Specialty & Automotive PVC Foam
- ISO 9001:2000 ISO/TS 16949:2002
- Quality Foam Seal products since 1977

Phone 800-380-0138 Email novagard@novagard.net
 Fax 216-881-5318 www.novagardsolutions.com



Solutions securing values™

We seal, damp and protect in demanding industrial environments, securing investments, processes and individuals worldwide.

www.trelleborg.com/Bencosafe www.trelleborg.com



THE VERSATILE SEALING SOLUTION

- Soft, low-density urethane foams
- Excellent air-, dust- and water-sealing properties
- Low force to compress — provides effective seals on rough or irregular surfaces

For more information or samples **E-A-R** Specialty Composites

- www.earsc.com/tufshield
- Toll-Free Solutions Hotline 877.EAR.IDEA

ATOM FLASHCUT HD30155
 Dieless Gasket Cutting System



Sales and Service Across North America
 www.RelcoInc.com 1-877-687-7614



YOUR SOURCE FOR GASKETS AND FABRICATION MATERIALS

525 West Congress Street - Pacific, MO 63069
 PH: (636) 257-2190 - www.globalapg.com

Pressure-Sensitive Adhesives



Specialty Tape Division

Fasten.
 Bond.
 Seal.

250 Chester Street
 Painesville, Ohio 44077
 Ph: 866-GO-AVERY/866-462-8379
 Fax: 440-358-3295
 URL: stus.averydennison.com
 e-mail: psa.tape@averydennison.com

Superior Adhesion and Faster, More Efficient Processing.

Put Unifilm® Transfer Adhesives to work for you.



(800) 801-0323
 www.scapana.com
 appsupport@scapana.com

O-Rings, Seals, Gaskets, EMI Shielding, Adhesives
 Custom Molded Rubber Parts, Sealants



4400 Walden Ave., Lancaster, NY 14086
 716-684-7600 * www.sealingdevices.com